

Průhledítko
přivařovací
AISI 304L, AISI 316L

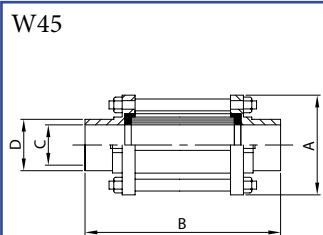

DN	A	B	C	D	Kg
1" 25	55,0	147,0	22,1	25,4	0,40
1 1/2" 38	70,0	153,0	34,8	38,1	0,62
2" 51	85,0	153,0	47,5	50,8	0,86
2 1/2" 63	95,0	163,0	60,2	63,5	0,95
3" 76	105,0	173,0	72,9	76,2	1,10
4" 101	140,0	173,0	97,4	101,6	2,76

Průhledítko
s konci CLAMP
AISI 304L, AISI 316L

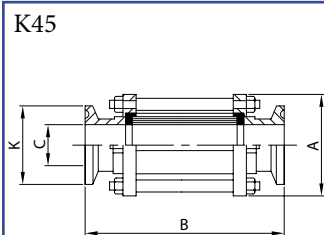

DN	A	B	C	K	Kg
1" 25	55,0	165,0	22,1	50,5	0,56
1 1/2" 38	70,0	165,0	34,8	50,5	0,76
2" 51	85,0	165,0	47,5	64,0	1,05
2 1/2" 63	95,0	165,0	60,2	77,5	1,18
3" 76	105,0	165,0	72,9	91,0	1,40
4" 101	140,0	165,0	97,4	119,0	3,26



Jiné provedení na poptávku - rozměry, připojení ...

T-průhledítko
přivařovací
AISI 304/L, AISI 316/L

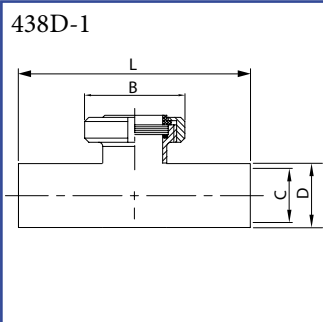

DN	B	C	D	L
25	63	25	28	100
32	70	31	34	110
40	78	37	40	120
50	92	49	52	140
65	112	66	70	160
80/65*	112	81	85	180
100/65*	112	100	104	200
125/100*	148	125	129	375
150/100*	148	150	154	450

T-průhledítko
přivařovací
AISI 304/L, AISI 316/L

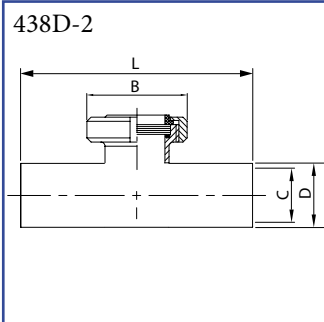

DN	B	C	D	L
25	63	26	29	100
32	70	32	35	110
40	78	38	41	120
50	92	50	53	140
65	112	66	70	160
80/65*	112	81	85	180
100/65*	112	100	104	200
125/100*	148	125	129	375
150/100*	148	150	154	450

Křížové průhledítko
přivařovací
AISI 304/L, AISI 316/L

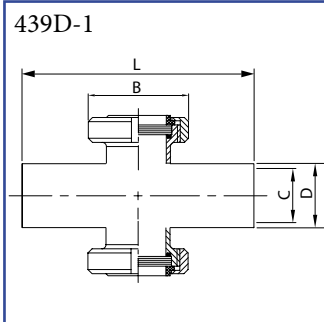

DN	B	C	D	L
25	63	25	28	100
32	70	31	34	110
40	78	37	40	120
50	92	49	52	140
65	112	66	70	160
80/65*	112	81	85	180
100/65*	112	100	104	200
125/100*	148	125	129	375
150/100*	148	150	154	450

Křížové průhledítko
přivařovací
AISI 304/L, AISI 316/L

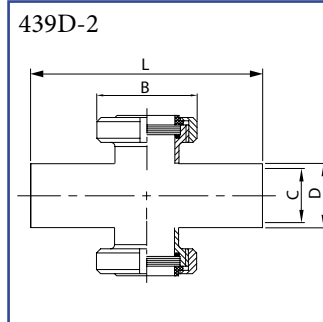

DN	B	C	D	L
25	63	26	29	100
32	70	32	35	110
40	78	38	41	120
50	92	50	53	140
65	112	66	70	160
80/65*	112	81	85	180
100/65*	112	100	104	200
125/100*	148	125	129	375
150/100*	148	150	154	450

* DN 80/65
DN průhledítka
DN T-kusu / kříže