

**3 PIECES STAINLESS STEEL CHECK VALVE (380-384)**



Management  
System  
ISO 9001 : 2015



**Size :** DN 8 to DN100  
**Ends :** Female-Female BSP or NPT, SW or BW  
**Min Temperature :** - 20°C  
**Max Temperature :** + 200°C  
**Max Pressure :** 63 Bars  
**Specifications :** 3 pieces spring type  
All positions  
Metal / metal

**Materials :** Stainless steel

**3 PIECES STAINLESS STEEL CHECK VALVE (380-384)**

**SPECIFICATIONS :**

3 pieces spring type  
All positions (respect the flow direction indicated by the arrow )  
Metal / metal tightness  
Stainless steel

**USE :**

Chemical and pharmaceutical industries, petrochemical industries, hydraulic installation, compressed air  
Min Temperature Ts : - 20°C  
Max Temperature Ts :+ 200°C  
Max Pressure Ps : 63 bars ( see graph under )  
Steam : 11 bars max

**PRESSURE / TEMPERATURE GRAPH ( STEAM EXCLUDED ) :**

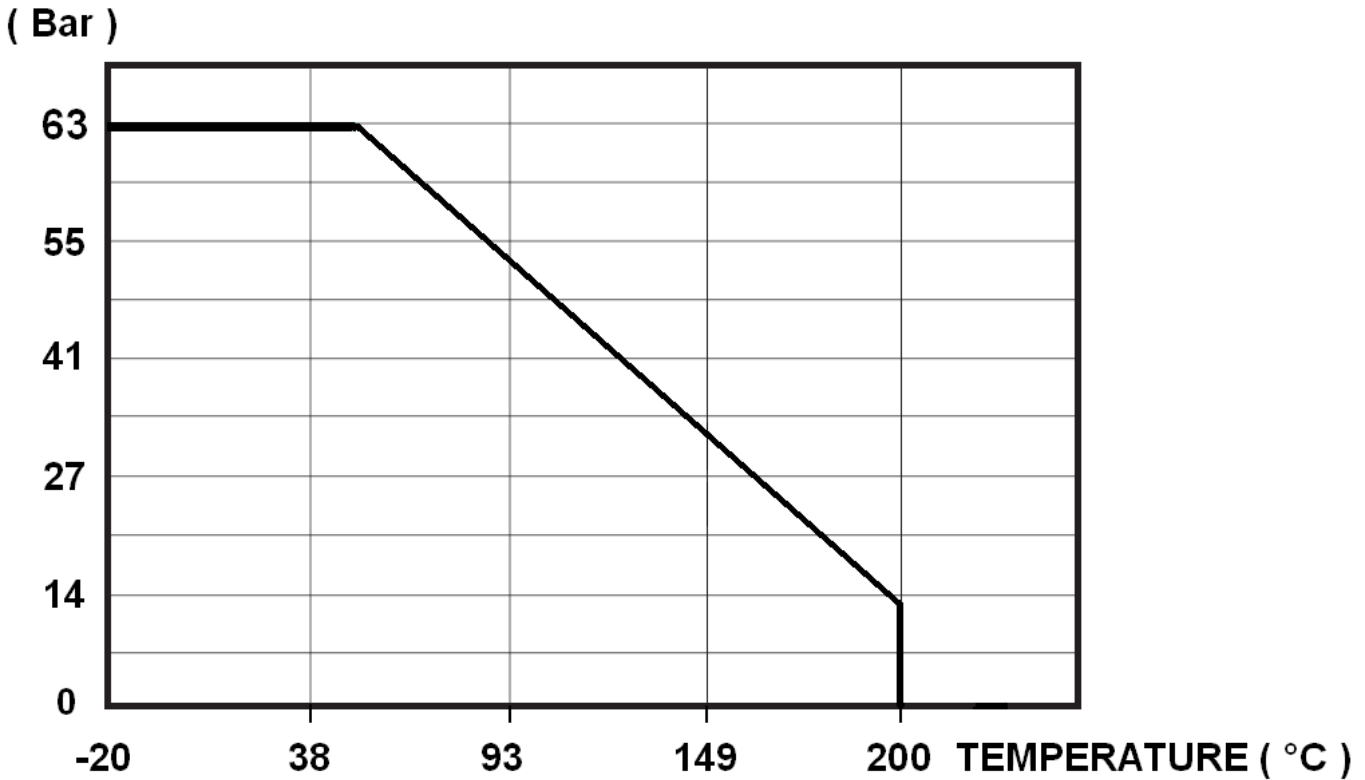

**FLOW COEFFICIENT Kvs ( M3 / h ) :**

DN	8	10	15	20	25	32	40	50	65	80	100
Kvs ( m3/h )	1.23	1.23	2.24	6.5	9.61	15.89	22.49	25.12	57.8	64.93	91.6

**3 PIECES STAINLESS STEEL CHECK VALVE (380-384)**

HEAD LOSS GRAPH :

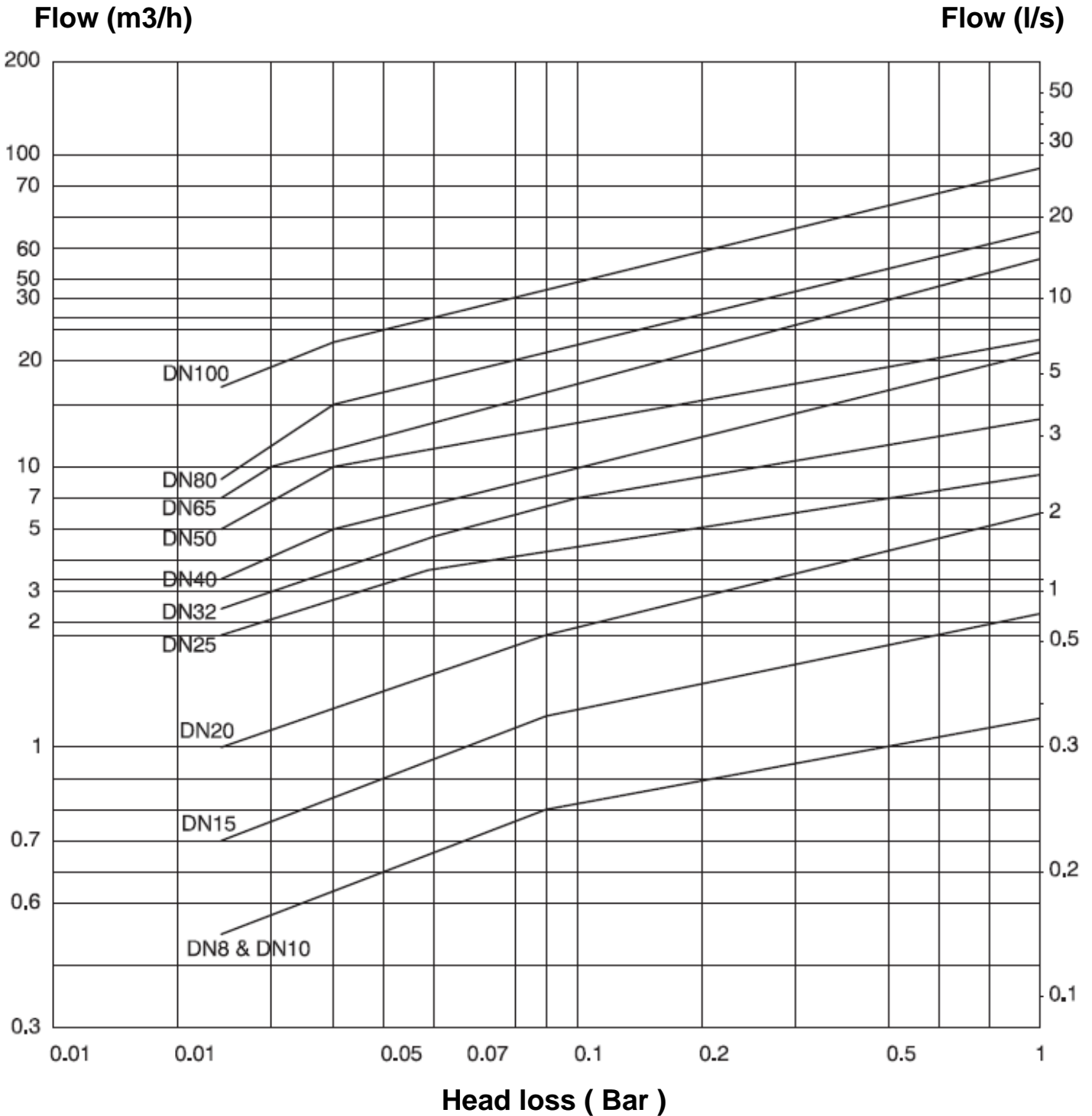

**3 PIECES STAINLESS STEEL CHECK VALVE (380-384)**

OPENING PRESSURE ( in mbar ) :

DN	Vertical Position ascending fluid	Horizontal Position
DN 08	25 ↑	23 →
DN 10	25 ↑	23 →
DN 15	25 ↑	23 →
DN 20	25 ↑	23 →
DN 25	25 ↑	23 →
DN 32	27 ↑	24 →
DN 40	29 ↑	25 →
DN 50	29 ↑	25 →
DN 65	31 ↑	25 →
DN 80	32 ↑	26 →
DN100	33 ↑	27 →

RANGE :

Female / female threaded BSP cylindrical **Ref. 380** from DN 1/4" to DN 4"

Butt Welding ends **Ref. 381** from DN 8 to DN 100

Socket Welding ends **Ref. 382** from DN 8 to DN100

Female threaded BSP cylindrical with SS316 strainer **Ref. 383** from DN 3/8" to DN 4" ( Ref. 380 + Ref. 391 )

Female / female threaded NPT **Ref. 384** from DN 1/4" to DN 2"

**3 PIECES STAINLESS STEEL CHECK VALVE (380-384)**

**MATERIALS :**

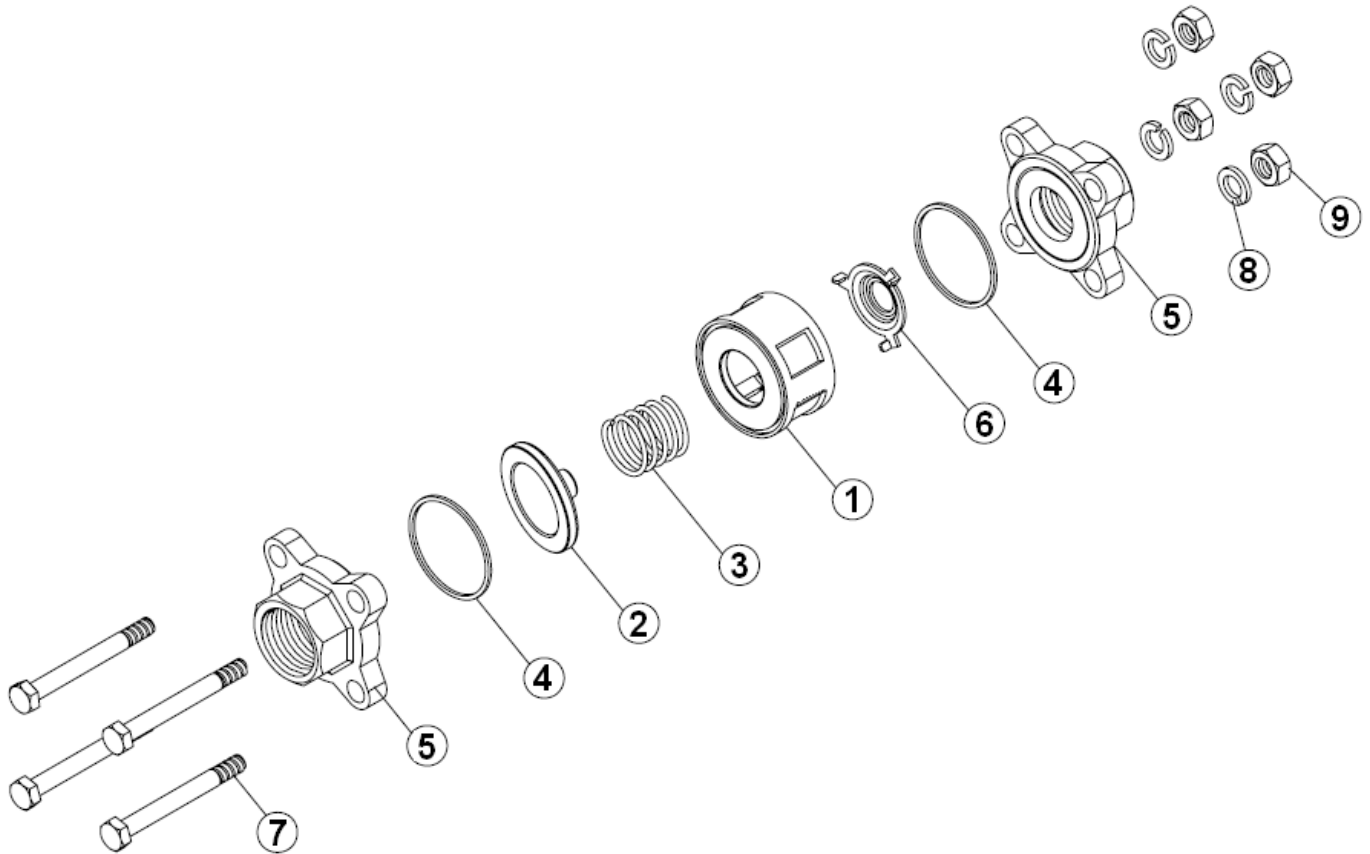

Item	Designation	Materials
1	Body	ASTM A351 CF8M
2	Disc	ASTM A240-316
3	Spring	AISI 316
4	Gasket	PTFE
5	Ends	ASTM A351 CF8M
6	Spring holder	ASTM A240-316
7	Screw	AISI 304
8	Washer	AISI 304
9	Nut	AISI 304

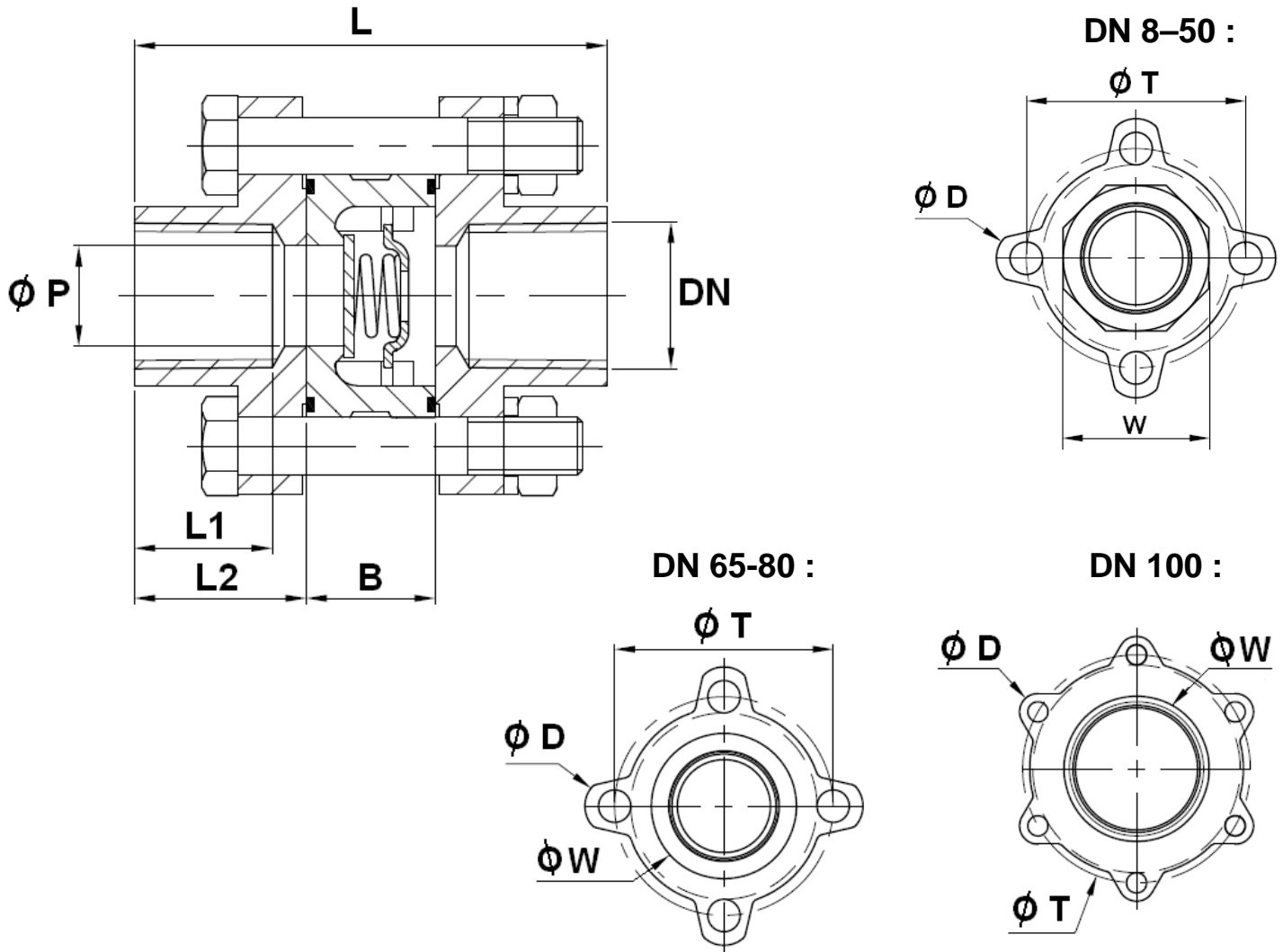
**3 PIECES STAINLESS STEEL CHECK VALVE (380-384)**
**SIZE THREADED TYPES ( in mm ) :**

Ref.	DN	1/4"	3/8"	1/2"	3/4"	1"	1"1/4	1"1/2	2"	2"1/2	3"	4"
380/384	Ø P	10	10	14	19	25	31	39	49	64	78	97
	L	60	60	63	71	81.5	91	97.5	117	131.5	143.5	174.5
	L1	16	16	18	20	20	23	23	27	33	35	45
	L2	21	21	22	23.5	26	29	30	35	42	44	52
	B	18	18	19	24	29.5	33	37.5	47	47.5	55.5	70.5
	Ø D	12	12	14	16	16	18	18	18	18	18	18
	Ø T	36.5	36.5	42.7	51.7	58.7	72.7	83.7	98.7	129	153.5	186.5
	W	22	22	26	32	39	49	56	69	83	100	122.5
	Weight ( Kg )	0.3	0.2	0.4	0.5	0.7	1.3	1.7	2.5	4.3	6.2	11

**3 PIECES STAINLESS STEEL CHECK VALVE (380-384)**

SIZE B.W. TYPE ( in mm ) :

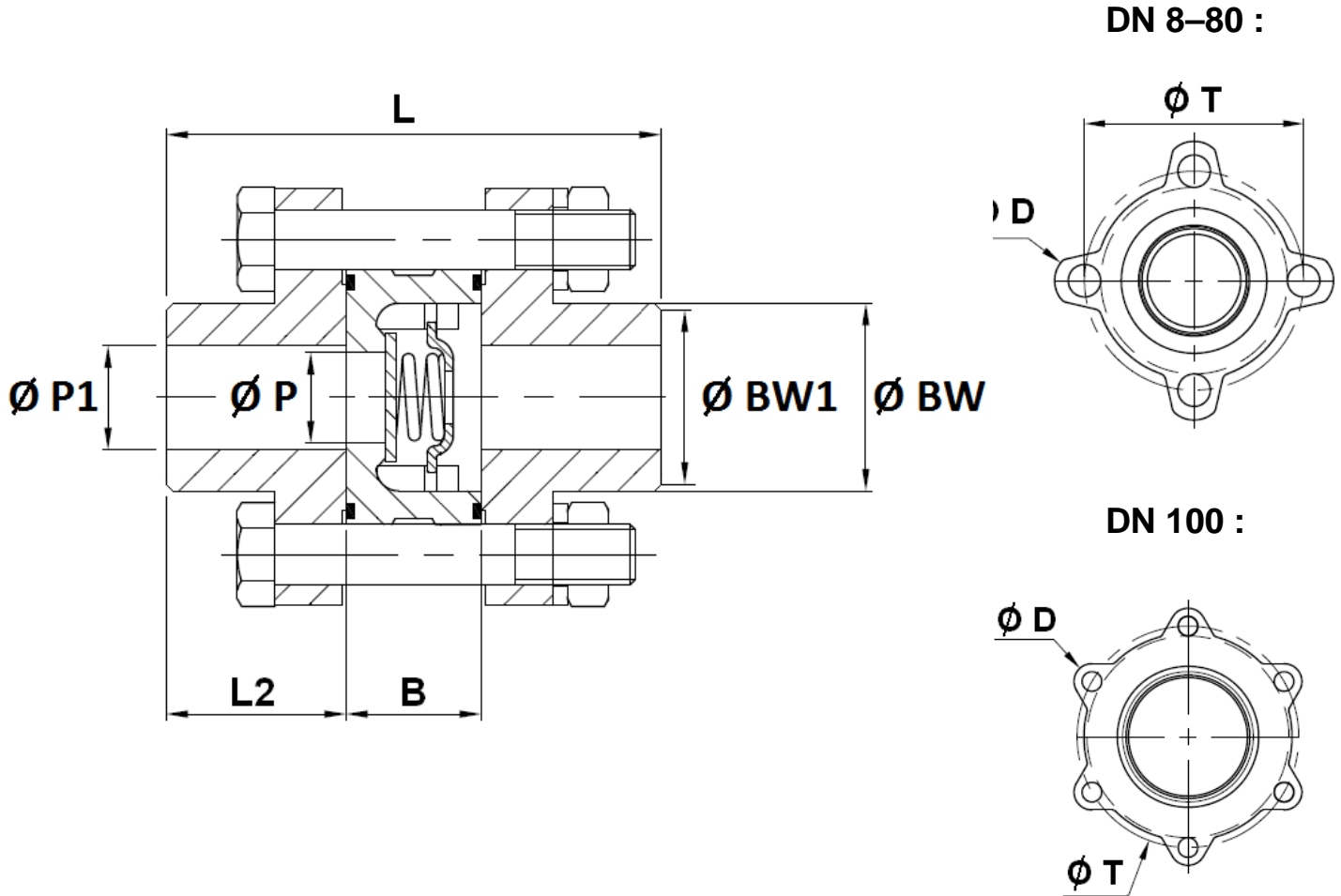

Ref.	DN	8	10	15	20	25	32	40	50	65	80	100
381	Ø P	10	10	14	19	25	31	39	49	64	78	97
	Ø P1	10	12.5	15	20	25	32	39	50	65	80	99.5
	L	66	66	67	81	89.5	92	103.5	117	131.5	143.5	174.5
	L2	24	24	24	28.5	30	29.5	33	35	42	44	52
	B	18	18	19	24	29.5	33	37.5	47	47.5	55.5	70.5
	Ø D	12	12	14	16	16	18	18	18	18	18	18
	Ø BW	18	20.5	22	28	31.5	40	46	60	78	91.5	121.5
	Ø BW1	14	16.8	18	23.3	28.5	35.8	41.2	53.5	69.4	84.1	104
	Ø T	36.5	36.5	42.7	51.7	58.7	72.7	83.7	98.7	129	153.5	186.5
	Weight ( Kg )		0.3	0.2	0.4	0.5	0.7	1.3	1.7	2.5	4.3	6.2

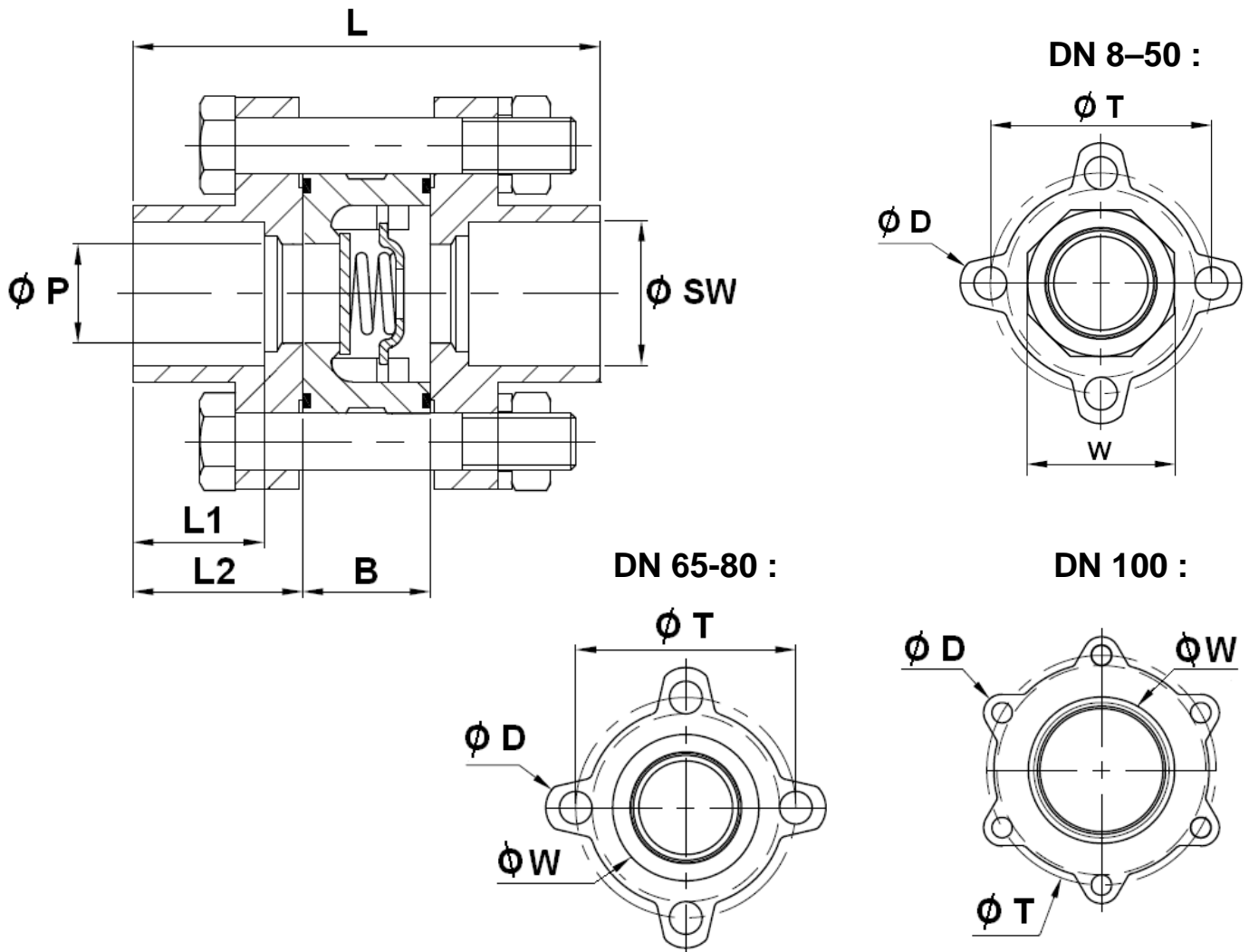

**3 PIECES STAINLESS STEEL CHECK VALVE (380-384)**
SIZE S.W. TYPE ( in mm ) :

Ref.	DN	8	10	15	20	25	32	40	50	65	80	100
382	Ø P	10	10	14	19	25	31	39	49	64	78	97
	L	60	60	63	71	81.5	91	97.5	117	131.5	143.5	174.5
	L1	15.5	16.5	12.5	14.1	15.7	17.7	19.5	22	26.3	28.7	37.5
	L2	21	21	22	23.5	26	29	30	35	42	44	52
	B	18	18	19	24	29.5	33	37.5	47	47.5	55.5	70.5
	Ø D	12	12	14	16	16	18	18	18	18	18	18
	W	22	22	26	32	39	49	56	69	83	100	122.5
	Ø SW	14.2	17.5	21.8	27.4	34.1	42.7	49	61	77	90.2	115.3
	Ø T	36.5	36.5	42.7	51.7	58.7	72.7	83.7	98.7	129	153.5	186.5
	Weight ( Kg )		0.3	0.2	0.4	0.5	0.7	1.3	1.7	2.5	4.3	6.2

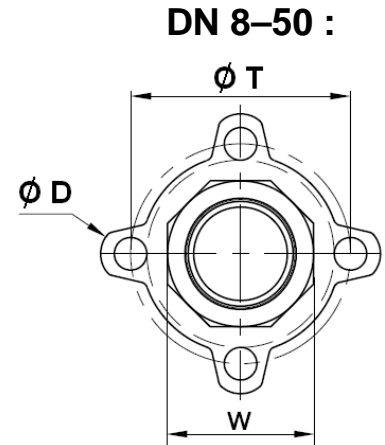
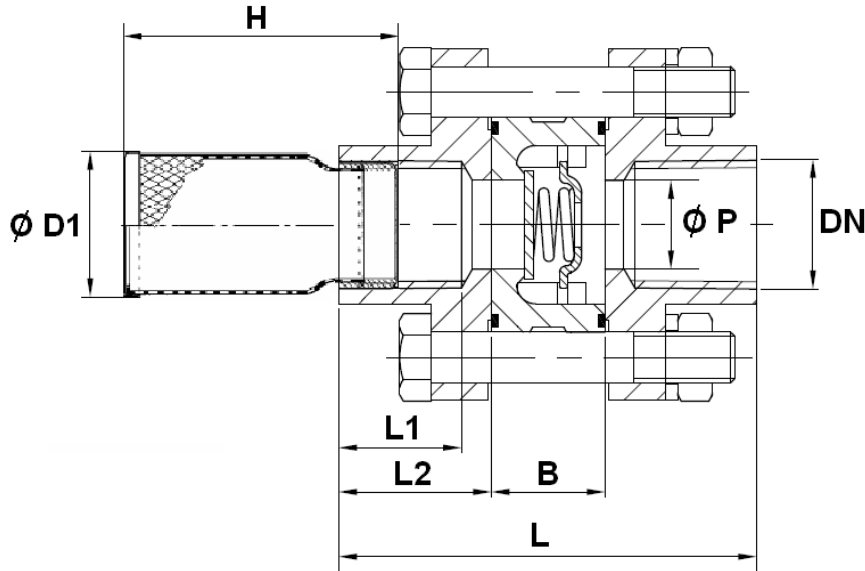
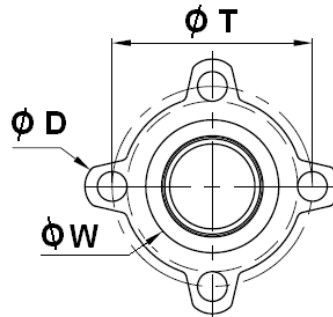
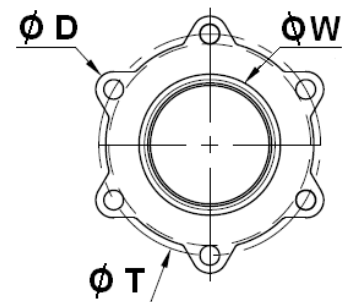

**3 PIECES STAINLESS STEEL CHECK VALVE (380-384)**
**SIZE THREADED TYPE WITH STRAINER ( in mm ):**

**DN 65-80 :**

**DN 100 :**

Ref .	DN	3/8"	1/2"	3/4"	1"	1"1/4	1"1/2	2"	2"1/2	3"	4"	
383	Ø P	10	14	19	25	31	39	49	64	78	97	
	L	60	63	71	81.5	91	97.5	117	131.5	143.5	174.5	
	L1	16	18	20	20	23	23	27	33	35	45	
	L2	21	22	23.5	26	29	30	35	42	44	52	
	B	18	19	24	29.5	33	37.5	47	47.5	55.5	70.5	
	Ø D1	21	23	29	37	44	49	61	80	86	116	
	H	51	55	62	69	80	89	101	114	126	144	
	Ø D	12	14	16	16	18	18	18	18	18	18	
	T	36.5	42.7	51.7	58.7	72.7	83.7	98.7	129	153.5	186.5	
	W	22	26	32	39	49	56	69	83	100	122.5	
	Mesh	1.2	1.2	1.2	1.2	1.2	1.2	1.2	1.2	1.5	1.5	2
	Weight ( Kg )		0.211	0.415	0.525	0.737	1.355	1.767	2.584	4.435	6.369	11.243

## 3 PIECES STAINLESS STEEL CHECK VALVE (380-384)

**BOLT TIGHTENING TABLE ( in Nm):**

DN	1/4"	3/8"	1/2"	3/4"	1"	1"1/4	1"1/2	2"	2"1/2	3"	4"
Torque ( Nm )	30	30	30	30	45	45	45	60	75	90	105

**STANDARDS :**

Fabrication according to ISO 9001 : 2015

DIRECTIVE 2014/68/UE : CE N° 0035  
 Risk category III Module H

Construction according to EN 12516-1

Designing according to ASME B16.34

Pressure tests according to API 598, table 6

BSP threaded cylindrical ends according to ISO 228-1

NPT threaded ends according to ANSI B1.20.1

BW ends according to DIN 3239

ATEX Group II Category 2 G/2D Zone 1 & 21 Zone 2 & 22 ( optional marking )

**ADVICE :** Our opinion and our advice are not guaranteed and SFERACO shall not be liable for the consequences of damages.  
 The customer must check the right choice of the products with the real service conditions.

## **3 PIECES STAINLESS STEEL CHECK VALVE (380-384)**

### **INSTALLATION INSTRUCTIONS**

#### **GENERAL GUIDELINES :**

Ensure that the check valves to be used are appropriate for the conditions of the installation (type of fluid, pressure and temperature).

Be sure to have enough valves to be able to isolate the sections of piping as well as the appropriate equipment for maintenance and repair.

Ensure that the check valves to be installed are of correct strength to be able to support the capacity of their usage.

**Installation of all circuits should ensure that their function can be automatically tested on a regular basis (at least two times a year).**

#### **INSTALLATION INSTRUCTIONS :**

**Before installing the check valves, clean and remove any objects from the pipes** (in particular bits of sealing and metal) which could obstruct and block the check valves.

**Ensure that both connecting pipes either side of the check valve (upstream and downstream) are aligned (if they're not, the valves may not work correctly).**

**Make sure that the two sections of the pipe (upstream and downstream) match, the check valve unit will not absorb any gaps. Any distortions in the pipes may affect the tightness of the connection, the working of the check valve and can even cause a rupture.** To be sure, place the kit in position to ensure the assembling will work.

**During welding operation, be sure to not exceed 200°C**

**If sections of piping do not have their final support in place, they should be temporarily fixed. This is to avoid unnecessary strain on the check valve.**

**Fluids in the check valve must not contain solid objects ( it could damaged the seat ).**

If there is a direction changing or if there's another material, it's better to take away the check valve so that it is outside the turbulence area ( **between 3 and 5 times the ND before and after** ).

After a pump please refer to **FD CEN/TR 13932** to install the check valve :

If it is essential to keep priming the pump, a non-return check valve can be fitted to the suction pipe at a distance **L1 ( straight length suction ) > 10xD1 (diameter suction )**

The check valve is designed to meet the maximum flow rate in service

In other cases, the non-return check valve is mounted on the discharge pipe at a distance of **L2 (straight length at discharge) > 3xD2 (diameter at discharge)**